

FORGED BRASS BALL VALVES

WITH 316L STAINLESS TUBE STUBS
AND OPTIONAL PURGE PORTS

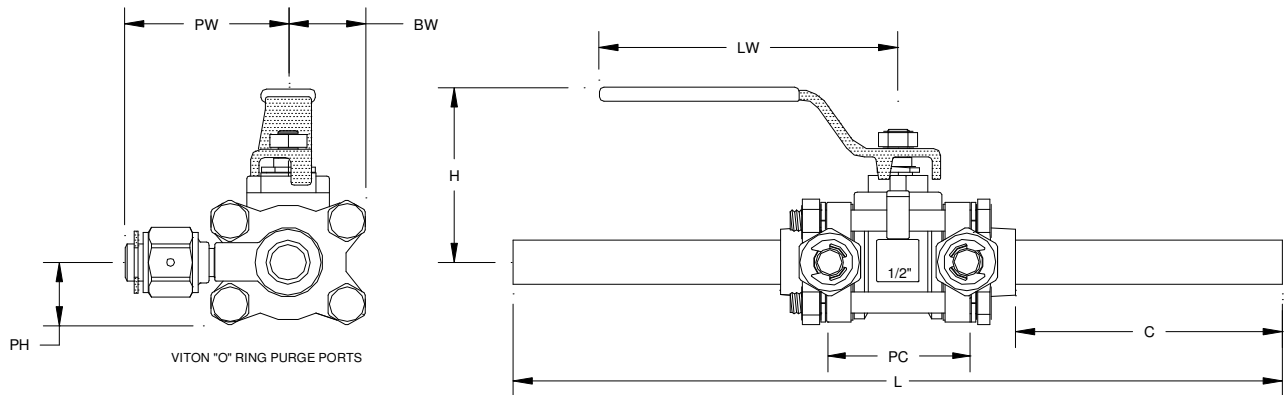

FORGED BRASS BALL VALVES WITH 316L STAINLESS TUBE STUBS

PART NUMBER	WALL	P W	B W	P H	P C	L W	H	L	C
W0500	0.049	1.918	0.918	0.682	1.750	3.375	1.875	8.375	2.867
W0750	0.049	2.000	1.000	1.000	2.125	4.500	2.250	8.750	2.774
W0750	0.065	2.000	1.000	1.000	2.125	4.500	2.250	8.750	2.774
W1000	0.065	2.093	1.093	1.093	2.375	4.500	2.375	11.000	2.812
W1500	0.065	2.500	1.500	1.320	2.125	5.250	3.000	18.000	6.875
W2000	0.065	2.915	1.915	1.500	2.362	5.250	3.250	18.562	6.500
W3000	0.083	3.375	3.375	4.750	3.083	6.375	3.875	21.125	7.333
W4000	0.083	3.375	3.375	4.750	3.612	9.000	4.250	22.875	5.612

NOTE: THE VALVE INTERNALS ARE NOT TO BE REMOVED PRIOR TO INERT GAS PURGE INSTALLATION.

ALL PRODUCTS ARE HELIUM LEAK TESTED TO 4.5×10^{-6} std cm^3/s

DANCAR CORPORATION - 145 N. Benson Road, Middlebury, CT 06762

Tel. (203) 598-0205 - Fax (203) 598-0211

dancar@dancar.com